



TECHNICAL SPECIFICATION

Bulletin : DRI-EDC-016-2
 Effective : March 18, 2009
 Supersedes : DRI-EDC-016-1
 Dated : Feb 08, 2007

DESICCANT ROTORS INTERNATIONAL PVT. LTD.

ARCTIC INDIA HOUSE, 20, RAJPUR ROAD, DELHI - 110054 (INDIA)

PHONE : 91-11-23906666 FAX: 91-11-23906600

E-MAIL: dri@pahwa.com, Website: www.drirotors.com



ECO-DRY DESICCANT CASSETTE

EDC SERIES (50, 100, 200 & 400mm DEPTH)

ECO-DRY DESICCANT CASSETTE (EDC 250-4250) COMES WITH ECO-DRY ROTOR
 ALL EDC SERIES UNIT HAVE THE FOLLOWING OUTSTANDING FEATURES

High efficiency and reliability

- * CNC fabricated unit(s) with powder coated finish.
- * High moisture removal capacity at relatively low energy cost.
- * Suitable for electrical, steam, thermic fluid, direct/indirect fired gas - reactivation source.
- * Rotor incorporates robust internal structure with perimeter flange for industrial quality and durability.
- * Rotor is water washable
- * Rotor perimeter flange extend media and seal life.
- * The rotor is made of alternate flat and corrugated inorganic fibre of very uniform pitch and height.

- * Rotor is non-flammable with organic<2%.
- * Hard face coating on rotor edge ensures long life and good sealing for media and seals.
- * Rotor depth 50, 100, 200 & 400mm.
- * Unique PTFE bonded bulb seal design minimizes air leakage.
- * Suitable for continuous operation.
- * Quick and easy to service.
- * Easy, access to all major components.
- * Quick serviceability and maintenance free operation.

PROCESS AND REACTIVATION RATIO

P & R RATIO	3:1	1:1
50mm ROTOR DEPTH	√	X
100mm ROTOR DEPTH	√	X
200mm ROTOR DEPTH	√	√
400mm ROTOR DEPTH	√	X

POWER REQUIREMENT

EDC 250 -370	1/85 Hp / 6W	115V/1PH/60HZ or 230V/3PH/50Hz.
EDC 440 -770	1/40 Hp / 25W	115V/1PH/50HZ or 230V/3PH/50Hz.
EDC 965 -2190	1/6 HP	220V/3PH/60Hz or 415V/3PH/50HZ
EDC 2450 -4250	1/4 HP	220V/3PH/60Hz or 415V/3PH/50HZ

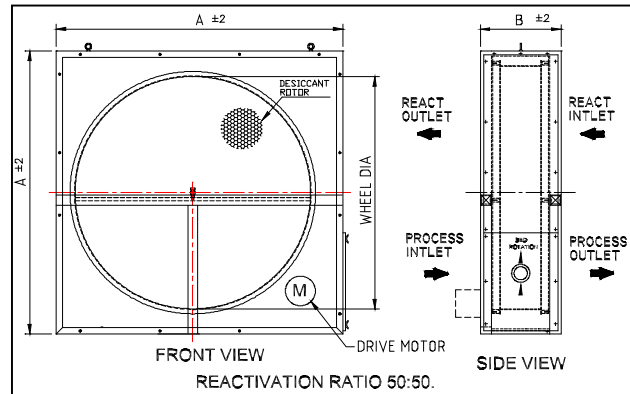
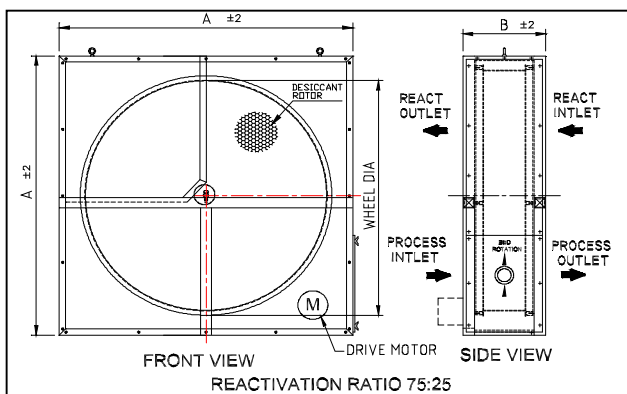

OPTIONS AVAILABLE

STAINLESS STEEL CONSTRUCTION	AVAILABLE ON REQUEST
SINGLE PHASE DRIVE	AVAILABLE ON REQUEST
HORIZONTAL MOUNTING	CONSULT FACTORY
LARGE SEGMENTED WHEELS	AVAILABLE ON REQUEST

Notes :-

1. 115V/1Ph/60Hz for USA Market
2. 230V/1Ph/50Hz for ASIAN Market

ALL DATA SUBJECT TO CHANGE WITHOUT NOTICE



ECO-DRY DESICCANT CASSETTE DATA (RATIO 75:25)

EDC 250-300 (ROTOR DEPTH-50mm)

S.NO.	MODEL	DIMENSIONS				NOMINAL PROCESS AIR VOLUME			APPROX WEIGHT (IN POUNDS.)	APPROX WEIGHT (IN KGS.)
		UNIT	WHEEL DIA	A	B	UNIT	Min @1.0 m/sec	Max. @2.0 m/sec		
1	EDC-250-50	inches	9.84	17.72	7.68	CFM	59	118	84	38
		mm	250	450	195	CMH	100	201		
2	EDC-300-50	inches	11.81	19.69	7.68	CFM	91	181	93	42
		mm	300	500	195	CMH	154	308		

EDC 250-370 (ROTOR DEPTH-100mm)

S.NO.	MODEL	DIMENSIONS				NOMINAL PROCESS AIR VOLUME			APPROX WEIGHT (IN POUNDS.)	APPROX WEIGHT (IN KGS.)
		UNIT	WHEEL DIA	A	B	UNIT	Min @1.0 m/sec	Max. @3.0 m/sec		
1	EDC-250-100	inches	9.84	17.72	9.65	CFM	59	177	88	40
		mm	250	450	245	CMH	100	301		
2	EDC-300-100	inches	11.81	19.69	9.65	CFM	91	272	99	45
		mm	300	500	245	CMH	154	462		
3	EDC-370-100	inches	14.57	22.44	9.65	CFM	145	436	112	51
		mm	370	570	245	CMH	247	741		

EDC 250-4250 (ROTOR DEPTH-200)

S.NO.	MODEL	DIMENSIONS				NOMINAL PROCESS AIR VOLUME			APPROX WEIGHT (IN POUNDS.)	APPROX WEIGHT (IN KGS.)
		UNIT	WHEEL DIA	A	B	UNIT	Min @2.0 m/sec	Max. @4.0 m/sec		
1	EDC-250-200	inches	9.84	17.72	13.58	CFM	118	237	99	45
		mm	250	450	345	CMH	201	402		
2	EDC-370-200	inches	14.57	22.44	13.58	CFM	291	581	128	58
		mm	370	570	345	CMH	494	988		
3	EDC-440-200	inches	17.32	25.20	13.58	CFM	424	849	148	67
		mm	440	640	345	CMH	721	1442		
4	EDC-550-200	inches	21.65	29.53	13.58	CFM	684	1368	181	82
		mm	550	750	345	CMH	1162	2324		
5	EDC-770-200	inches	30.31	38.19	13.58	CFM	1369	2738	265	120
		mm	770	970	345	CMH	2327	4653		
6	EDC-965-200	inches	37.99	45.87	15.55	CFM	2146	4292	344	156
		mm	965	1165	395	CMH	3646	7293		
7	EDC-1220-200	inches	48.03	55.91	15.55	CFM	3496	6992	478	217
		mm	1220	1420	395	CMH	5941	11881		
8	EDC-1525-200	inches	60.04	66.93	15.55	CFM	5506	11012	662	300
		mm	1525	1700	395	CMH	9356	18712		
9	EDC-1740-200	inches	68.50	75.20	15.55	CFM	7165	14329	919	417
		mm	1740	1910	395	CMH	12174	24349		
10	EDC-1940-200	inches	76.38	83.27	15.55	CFM	8970	17939	1080	490
		mm	1940	2115	395	CMH	15242	30483		
11	EDC-2190-200	inches	86.22	93.11	15.55	CFM	11507	23014	1274	578
		mm	2190	2365	395	CMH	19553	39106		
12	EDC-2450-200	inches	96.46	104.33	16.73	CFM	14410	28820	1665	755
		mm	2450	2650	425	CMH	24486	48972		
13	EDC-2650-200	inches	104.33	112.20	16.73	CFM	16924	33848	1865	846
		mm	2650	2850	425	CMH	28758	57516		
14	EDC-2950-200	inches	116.14	124.02	16.73	CFM	21069	42139	2183	990
		mm	2950	3150	425	CMH	35802	71604		
15	EDC-3550-200	inches	139.76	147.64	16.73	CFM	30708	61416	2999	1360
		mm	3550	3750	425	CMH	52180	104360		
16	EDC-3950-200	inches	155.51	163.39	16.73	CFM	38132	76264	3541	1606
		mm	3950	4150	425	CMH	64795	129590		
17	EDC-4250-200	inches	167.32	175.20	16.73	CFM	44224	88448	3978	1804
		mm	4250	4450	425	CMH	75147	150294		

EDC 550-4250 (ROTOR DEPTH-400mm)

S.NO.	MODEL	DIMENSIONS				NOMINAL PROCESS AIR VOLUME			APPROX WEIGHT (IN POUNDS.)	APPROX WEIGHT (IN KGS.)
		UNIT	WHEEL DIA	A	B	UNIT	Min @2.0 m/sec	Max. @4.0 m/sec		
1	EDC-550-400	inches	21.65	29.53	21.46	CFM	669	1338	251	114
		mm	550	750	545	CMH	1137	2273		
2	EDC-770-400	inches	30.31	38.19	21.46	CFM	1369	2738	368	167
		mm	770	970	545	CMH	2327	4653		
3	EDC-965-400	inches	37.99	45.87	23.43	CFM	2146	4292	485	220
		mm	965	1165	595	CMH	3646	7293		
4	EDC-1220-400	inches	48.03	55.91	23.43	CFM	3452	6904	750	340
		mm	1220	1420	595	CMH	5866	11732		
5	EDC-1525-400	inches	60.04	66.93	23.43	CFM	5493	10987	1021	463
		mm	1525	1700	595	CMH	9334	18669		
6	EDC-1740-400	inches	68.50	75.20	23.43	CFM	7165	14329	1323	600
		mm	1740	1910	595	CMH	12174	24349		
7	EDC-1940-400	inches	76.38	83.27	23.43	CFM	8970	17939	1577	715
		mm	1940	2115	595	CMH	15242	30483		
8	EDC-2190-400	inches	86.22	93.11	23.43	CFM	11507	23014	1890	857
		mm	2190	2365	595	CMH	19553	39106		
9	EDC-2450-400	inches	96.46	104.33	24.61	CFM	14410	28820	2646	1200
		mm	2450	2650	625	CMH	24486	48972		
10	EDC-2650-400	inches	104.33	112.20	24.61	CFM	16924	33848	2983	1353
		mm	2650	2850	625	CMH	28758	57516		
11	EDC-2950-400	inches	116.14	124.02	24.61	CFM	21069	42139	3524	1598
		mm	2950	3150	625	CMH	35802	71604		
12	EDC-3550-400	inches	139.76	147.64	24.61	CFM	30577	61154	4838	2194
		mm	3550	3750	625	CMH	51958	103915		
13	EDC-3950-400	inches	155.51	163.39	24.61	CFM	38001	76002	5759	2612
		mm	3950	4150	625	CMH	64573	129145		
14	EDC-4250-400	inches	167.32	175.20	24.61	CFM	44093	88186	6505	2950
		mm	4250	4450	625	CMH	74925	149849		

ALL DATA SUBJECT TO CHANGE WITHOUT NOTICE

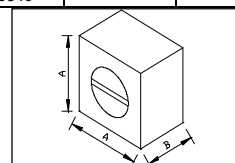

ECO-DRY DESICCANT CASSETTE DATA (RATIO 50:50)

EDC 250-4250 (ROTOR DEPTH-200)

S.NO.	MODEL	DIMENSIONS				NOMINAL PROCESS AIR VOLUME			APPROX WEIGHT (IN POUNDS)	APPROX WEIGHT (IN KGS.)
		UNIT	WHEEL DIA	A	B	UNIT	Min @2.0 m/sec	Max. @4.0 m/sec		
1	EDC-250-200	inches	9.84	17.72	13.58	CFM	79	158	99	45
		mm	250	450	345	CMH	134	268		
2	EDC-370-200	inches	14.57	22.44	13.58	CFM	194	387	128	58
		mm	370	570	345	CMH	329	658		
3	EDC-440-200	inches	17.32	25.20	13.58	CFM	283	566	148	67
		mm	440	640	345	CMH	481	961		
4	EDC-550-200	inches	21.65	29.53	13.58	CFM	456	912	181	82
		mm	550	750	345	CMH	775	1550		
5	EDC-770-200	inches	30.31	38.19	13.58	CFM	913	1826	265	120
		mm	770	970	345	CMH	1551	3102		
6	EDC-965-200	inches	37.99	45.87	15.55	CFM	1431	2861	344	156
		mm	965	1165	395	CMH	2431	4862		
7	EDC-1220-200	inches	48.03	55.91	15.55	CFM	2331	4661	478	217
		mm	1220	1420	395	CMH	3960	7921		
8	EDC-1525-200	inches	60.04	66.93	15.55	CFM	3671	7341	662	300
		mm	1525	1700	395	CMH	6237	12474		
9	EDC-1740-200	inches	68.50	75.20	15.55	CFM	4776	9553	919	417
		mm	1740	1910	395	CMH	8116	16232		
10	EDC-1940-200	inches	76.38	83.27	15.55	CFM	5980	11960	1080	490
		mm	1940	2115	395	CMH	10161	20322		
11	EDC-2190-200	inches	86.22	93.11	15.55	CFM	7671	15343	1274	578
		mm	2190	2365	395	CMH	13035	26071		
12	EDC-2450-200	inches	96.46	104.33	16.73	CFM	9607	19213	1665	755
		mm	2450	2650	425	CMH	16324	32648		
13	EDC-2650-200	inches	104.33	112.20	16.73	CFM	11283	22565	1865	846
		mm	2650	2850	425	CMH	19172	38344		
14	EDC-2950-200	inches	116.14	124.02	16.73	CFM	14046	28093	2183	990
		mm	2950	3150	425	CMH	23868	47736		
15	EDC-3550-200	inches	139.76	147.64	16.73	CFM	20472	40944	2999	1360
		mm	3550	3750	425	CMH	34787	69573		
16	EDC-3950-200	inches	155.51	163.39	16.73	CFM	25421	50842	3541	1606
		mm	3950	4150	425	CMH	43197	86393		
17	EDC-4250-200	inches	167.32	175.20	16.73	CFM	29483	58965	3978	1804
		mm	4250	4450	425	CMH	50098	100196		

